

Fabric Drape Prediction Using Artificial Neural Networks and Finite Element Method

Hassen Hedfi¹, Adel Ghith² and Hédi BelHadjSalah¹

¹University of Monastir, National Engineering School of Monastir, Mechanical Engineering Laboratory, Tunisia

²University of Monastir, National Engineering School of Monastir, Thermal and Energetic Systems Studies Laboratory, Tunisia

hassen_hedfi@yahoo.com

Abstract— In this paper the mechanical behavior of woven materials is investigated in order to study and predict their dynamic draping. This model can simulate fabric deformation, taking into account its physical and mechanical properties. Once the model is tested and validated, an artificial neural network designed to train fabric drape is coupled with the finite element model to predict the drape behavior of various fabrics. The designed artificial neural network predicts physical and mechanical properties of the fabric from its technical parameters (design parameters). The predicted properties are used as inputs for finite element model that simulates and calculates parameters related to the fabric drape. The process is repeated until the difference between the actual drape and the simulated one becomes smaller than a limit value.

Index Terms— Artificial Neural Network, fabric drape, Finite Element Method, prediction and optimization

1 INTRODUCTION

FOR the past three decades, textile fabrics have not only the traditional role of clothing or home furnishings, but they become more and more genuine support for artistic creation and technological innovation [1]. Therefore, to satisfy the consumers has become a task increasingly difficult to achieve. As a result, the adoption of new methodology for the design and manufacture of clothing has become a key requirement [2]. As for example, Tokumaru et al. [3] proposed a system named “Virtual Stylist”, which aims to help users find out their favorite clothes, which might fit them well. The system is composed of 3 parts as follows, (i) searching clothes in consideration of their color scheme harmonies and image sensations, (ii) adopting rules for evaluating color scheme image sensations to a specific user’s feeling of color images, (iii) virtual fitting system. Guerlain and Durand [4] analysed several methods developed, evaluated and used as part of a 3D electronic tailor especially adapted to the clothing industry. Hu, et al. [5] proposed an immune-inspired interactive co-evolutionary CAD system. They gave the functionality model, modular architecture and data flow of the system. They also proposed the flow of co-design in the system. As a case demonstration, the authors studied a design sample of a leisure shirt. The experimental studies show that this approach has promising

performance and appealing effects.

Moreover, given the constant development of computer’s tools and e-commerce, it became advantageous to develop virtual platforms for interactive design of clothes, real-time visualization and virtual Try-On [6].

Lau *et al.* [9] used fuzzy expert system with gradient descent optimization for prediction of fabric specimens in fashion product development. Unlike traditional methods which used fabric mechanical properties to predict fabric specimens, this fuzzy method accepts fabric hand descriptors which are more closely related to the sensory judgments made by individuals during fabric selection. The prediction accuracy is over eighty percent. Hadjianfar and Semnani [10] studied the textile fabrics’ luster. In their method, different fabric samples are classified in six different classes based on the luster determined by judgment of ten different inspectors. The luster index, obtained by the use of image processing, is then classified in six fuzzy classes based on fuzzy logic theory. Results prove that fuzzy classification is confirmed by viewers’ judgments. More details on the use of intelligent methods in the textiles field may be found in [11], [12], [13].

In this context, several research papers are interested in modeling and simulation of textile fabrics in order to predict and assess their drape.

1.1 Related work

Fabric drape is among the most important properties related to the aesthetics of clothing and home furnishings. This exhibits comfort and satisfaction sensations among consumers and increases the marketing of textile goods.

Textile fabric drape means the manner in which a fabric is deformed under the effect of its own weight when attached by one of its parts. The drape is generally characterized by the formation of folds with curves having various shapes and different geometric dimensions.

Stylios et al. [14] investigated the fabric drapability. In this study, the drape attributes of fabrics (drape coefficient, number, depth and evenness of folds) were measured. The relationship between these measurements and the subjective evaluation of the fabric drape were modeled for each end-use on a neural network using back propagation, which can correctly predict the grades of 90% of the samples. The relationship between the drape attributes and fabric bending, shear and weight was also modeled using neural networks. It was found that using the natural logarithm of the material property divided first by the weight of the fabric produced the most predictive model.

Lam et al. [15] used Artificial Neural Networks (ANN) to predict the Drape Coefficient (DC) and Circularity (CIR) of many different kinds of fabrics. Two ANN models were used: the Multilayer Perceptron using Backpropagation (BP) and the Radial Basis Function (RBF). The BP method was found to be more efficient than the RBF one but the RBF method was the fastest when it came to training. Comparisons of the two models as well as comparisons of the same models using different parameters are presented. The authors found that prediction for CIR was less accurate than for DC for both neural network architectures.

Behera and Mishra [16] proposed an engineered approach to fabric development in which a radial basis function network is trained with worsted fabric constructional parameters to predict functional and aesthetic properties of fabrics. An objective method of fabric appearance evaluation with the help of digital image processing is introduced. The prediction of fabric properties by the network with changing basic fibre characteristics and fabric constructional parameters is found to have good correlation with the experimental values of fabric functional and aesthetic properties.

Jedda et al. [17] investigated the relationship between the fabric drape coefficient measured using drape meter and

mechanical properties obtained by experimental device: the Fabric Assurance by Simple Testing system (FAST). Different types of woven fabrics were tested. Three regression models are proposed using the multiple linear regressions. The regression results were analyzed and compared with those obtained from a neural model used to predict fabric drape. More accuracy is obtained with neural network model.

Pattanayak et al. [18] used an instrument based on a digital image processing technique to measure drape parameters and the Kawabata evaluation system (KES-F) to assess the low stress mechanical properties. They, then, predicted the drape parameters using multiple regressions method and feed-forward back-propagation neural network technique. Simple equations are derived using regressions method to predict the five shape parameters of drape profile (drape coefficient, drape distance ratio, fold depth index, amplitude and number of nodes) from the low stress mechanical properties. The authors claimed that bending, shear and aerial density affect the drape parameters most whereas the tensile and compression have little effect on the drape parameters.

1.2 Our Proposal

In this paper, we propose to use the technical and physical parameters to predict mechanical properties of textile fabric by means of Artificial Neural Network. Then, these properties are used as inputs for Finite Element Model. The parameters of draped fabrics are then obtained by numerical simulation. The artificial neural network is tuned by comparison between the actual and simulated drape. In this way, we will not need to determine the mechanical properties of textile fabrics experimentally.

1.3 Organization

In the next section, we briefly develop the finite element modeling of textile fabrics. Then we present the neural networks used for learning the fabric drape and the ANN-FEM coupling. Results and discussions will be the subject of the last paragraph.

2 FABRIC FINITE ELEMENT MODELING

A fabric is obtained by intercrossing two sets of yarn: the warp and weft yarn, according to a weave pattern. Several parameters would be set to obtain a fabric with mechanical, physical and aesthetic properties appropriate to the end-use of these fabrics.

2.1 Woven Fabric Characterization

The characterization of textile fabrics includes:

1. **Technical parameters**, which deals with:
 - a. **Weave pattern**

It is the manner in which the warp and weft yarns are intercrossed to form a strong textile surface: the woven fabric. Several types of weave patterns are used for weaving. The most common weave patterns, also known as basic, are plain (Fig. 1), twill (Fig. 2) and satin (Fig. 3).

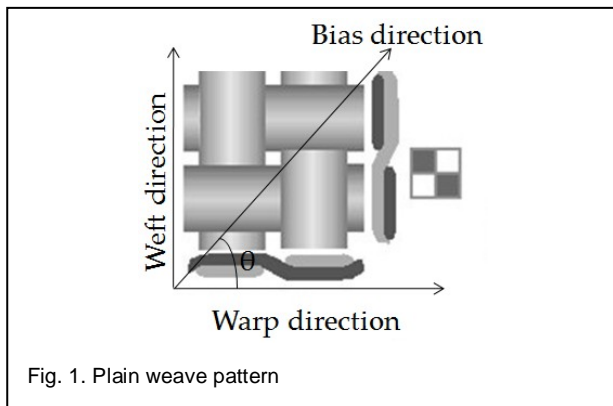

Fig. 1. Plain weave pattern

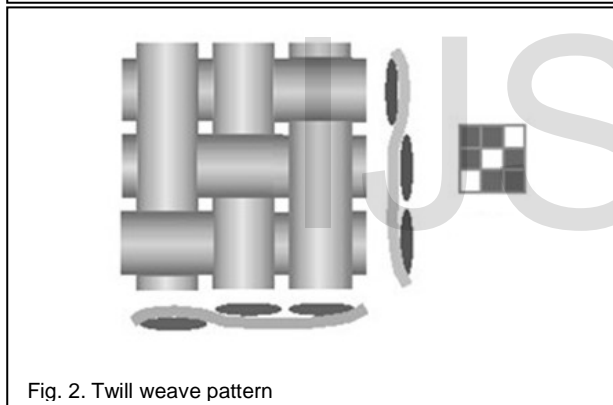

Fig. 2. Twill weave pattern

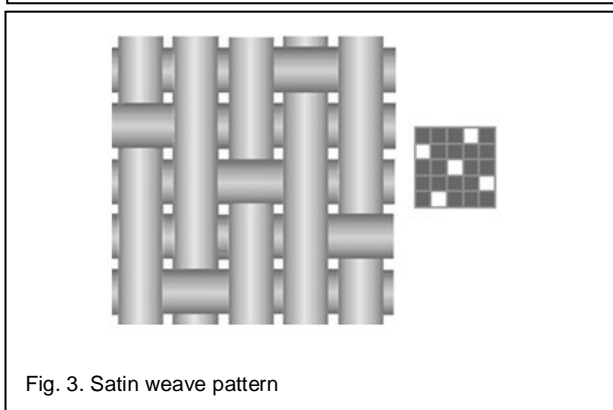

Fig. 3. Satin weave pattern

b. Fabric density

Fabric density includes warp density (WpD) and weft density (WtD). Each is a measure of number of yarns per unit of length of the fabric in due direction. The units for warp density are: ends/cm, ends/10cm, or ends/inch;

and for weft density: picks/cm, picks/10cm, or picks/inch. Fabric density indicates the tightness of the fabric for given yarn count.

c. Warp count (WpC)

The warp count is a number indicating the mass per unit length, or the length per unit mass of warp yarn. It indicates the fineness of warp yarn. The unit used can be the Nm - Metric system, in this case warp count is the No of 1000 meters length per kg of warp yarn.

d. Weft count (WtC)

The weft count is a number indicating the mass per unit length, or the length per unit mass of weft yarn. It indicates the fineness of weft yarn. The unit used can be the Nm - Metric system, in this case weft count is the No of 1000 meters length per kg of weft yarn.

2. **Physical characterization**, which deals with the determination of:

- a. **Mass density ρ ($g\ m^{-2}$)**: The measurement is performed as follows: we cut a square part of the fabric of known area and we weigh the sample using a precision balance. The test is repeated 5 times and an average value is calculated.

- b. **Thickness** of the fabric is denoted δ (mm)

3. **Mechanical characterization**, which deals with the determination of:

- a. **The Young's moduli (MPa)** in the warp (E_{wp}), weft (E_{wt}) and bias (E_{bias}) directions

- b. **The Poisson's ratios** in the warp (ν_{wp}) and weft (ν_{wt}) directions

- c. **The shear modulus H (MPa)**, calculated as following:

$$H = \left(\frac{4}{E_{bias}} - \frac{1 - \nu_{wt}}{E_{wp}} - \frac{1 - \nu_{wp}}{E_{wt}} \right)^{-1} \quad (1)$$

- d. **The flexural moduli (μNm)** in the directions: warp (Rf_{wp}) and weft (Rf_{wt})

4. **Fabric drape characterization**, which deals with the determination of:

- a. Node Number (NN)

- b. Drap coefficient DC:

$$DC(\%) = \frac{r_m^2 - r_s^2}{r_u^2 - r_s^2} \times 100 \quad (2)$$

- c. Drap Distance Ratio

$$DDR(\%) = \frac{r_u^2 - r^{-2}}{r_u^2 - r_s^2} \times 100 \quad (3)$$

- d. Fold Depth Index

$$FDI(\%) = \frac{r_{\max} - r_{\min}}{r_u - r_s} \times 100 \quad (4)$$

e. Amplitude to Radius

$$AR = \frac{r_{\max} - r_{\min}}{2} \quad (5)$$

Where r_u : The radius of undraped fabric, r_s the radius of the fabric supporting-disc, r_m the average of 16 measured rays between disc centre and projected profile:

$$r_m = \frac{1}{16} \sum_{i=1}^{16} r_i \quad (6)$$

$$r_{\max} = \max(r_i), r_{\min} = \min(r_i) \quad (7)$$

2.2 The Model

The equation of motion of the surface of the textile fabric can be formulated as follows: [19]

$$\rho \frac{\partial^2 \vec{r}}{\partial t^2} + \mu \frac{\partial \vec{r}}{\partial t} + \vec{f}^{\text{int}} = \vec{f}^{\text{ext}} \quad (8)$$

Where,

ρ : The surface density ($kg\ m^{-2}$)

μ : The damping density ($Kg\ m^{-2}\ s^{-1}$)

\vec{r} : The vector of instantaneous position of a point P belonging on the fabric surface. We have $\vec{r} = \vec{r}(a_1, a_2, t)$, $(a_1, a_2) \in \Omega^2$ denote the parametric variables, defined on parametric domain $\Omega^2 \subset R^2$, and t indicate the time.

\vec{f}^{int} : The internal elastic forces resulting of the deformation occurred in the fabric during motion or when interacting with other solid object or with fluid flow.

$$\vec{f}^{\text{int}} = - \sum_{\alpha, \beta=1}^2 \frac{\partial}{\partial a_\alpha} \left(S_{\alpha\beta} \cdot \frac{\partial \vec{r}}{\partial a_\alpha} \right) + \sum_{\alpha, \beta=1}^2 \frac{\partial^2}{\partial a_\alpha \partial a_\beta} \left(C_{\alpha\beta} \cdot \frac{\partial^2 \vec{r}}{\partial a_\alpha \partial a_\beta} \right) \quad (9)$$

Where, $S_{\alpha\beta} = w_{\alpha\beta}^s (g_{\alpha\beta}^t - g_{\alpha\beta}^0)$ and $C_{\alpha\beta} = w_{\alpha\beta}^b (b_{\alpha\beta}^t - b_{\alpha\beta}^0)$. These coefficients describe material properties: $w_{\alpha\beta}^s$, for stretch and shear behaviour, and $w_{\alpha\beta}^b$, for bending.

$$w_{11}^s = E_{wp}, w_{12}^s = H, w_{21}^s = H, w_{22}^s = E_{wt} \quad (10)$$

$$w_{11}^b = Rf_{wp}, w_{12}^b = w_{21}^b = 0, w_{22}^b = Rf_{wt} \quad (11)$$

To describe fabric deformations, two tensors of surface are used: euclidian tensor G and curvature tensor B .

$$G = (g_{\alpha\beta})_{1 \leq \alpha, \beta \leq 2}, g_{\alpha\beta} = \frac{\partial \vec{r}}{\partial a_\alpha} \cdot \frac{\partial \vec{r}}{\partial a_\beta}; \quad (12)$$

$$B = (b_{\alpha\beta})_{1 \leq \alpha, \beta \leq 2}, b_{\alpha\beta} = \frac{\partial^2 \vec{r}}{\partial a_\alpha \partial a_\beta} \cdot \vec{n} \quad (13)$$

Where \vec{n} denote the unit surface normal:

$$\vec{n} = \frac{\frac{\partial \vec{r}}{\partial a_1} \times \frac{\partial \vec{r}}{\partial a_2}}{\left\| \frac{\partial \vec{r}}{\partial a_1} \times \frac{\partial \vec{r}}{\partial a_2} \right\|} \quad (14)$$

\vec{f}^{ext} : The external forces such as gravitational force $\vec{f}^g = \rho \vec{g}$, \vec{g} gravitational acceleration.

Equation 8 is solved using the finite element method. Details of the resolution algorithm and numerical results are reported in [19].

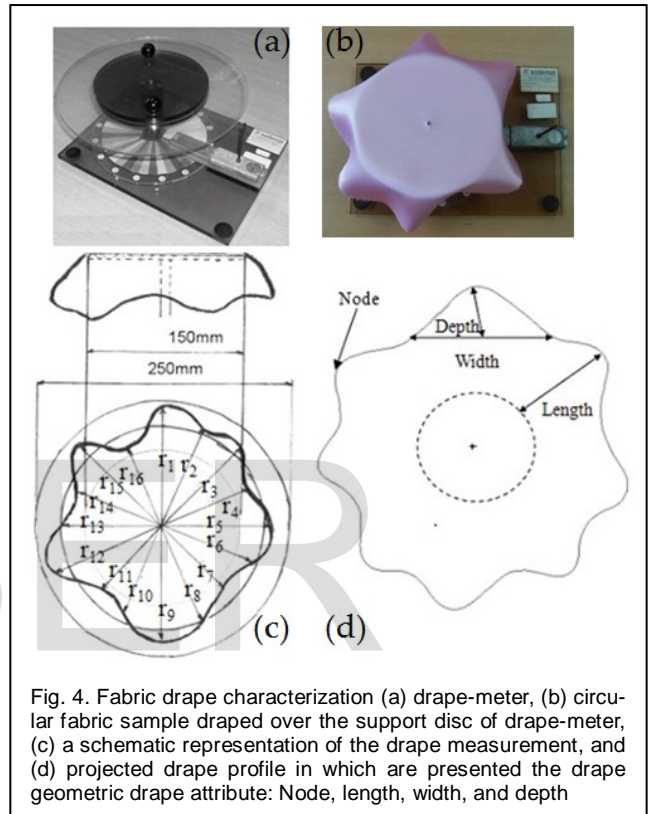

Fig. 4. Fabric drape characterization (a) drape-meter, (b) circular fabric sample draped over the support disc of drape-meter, (c) a schematic representation of the drape measurement, and (d) projected drape profile in which are presented the drape geometric drape attribute: Node, length, width, and depth

3 ANN FOR FABRIC DRAPE LEARNING

3.1 Parameters Learning

Artificial Neural Networks (ANN) is used to predict mechanical of textile fabrics from technical and physical parameters. The learning database consists of a wide variety of textile fabrics. These fabrics are characterized in terms of technical parameters (or parameters of construction), mechanical, physical properties and in terms of drape properties (or drape attributes).

All ANN inputs and outputs are normalized before training step using following formula:

$$t_i^n = \frac{t_i - \bar{t}_i}{\sigma_i} \quad (15)$$

Where, t_i^n the normalized values of parameter i , t_i the measured values of parameter i , \bar{t}_i its average, and σ_i its standard deviation. After normalization, each parameter has an average of 0 and a standard deviation equal to 1.

Experimental database is a divided randomly into three subsets:

1. Training subset containing 70% of samples used for gradient computing and for ANN weights and biases updating.
2. Validation subset containing 15% of samples
3. Test subset containing 15% of samples, used for ANN generalization

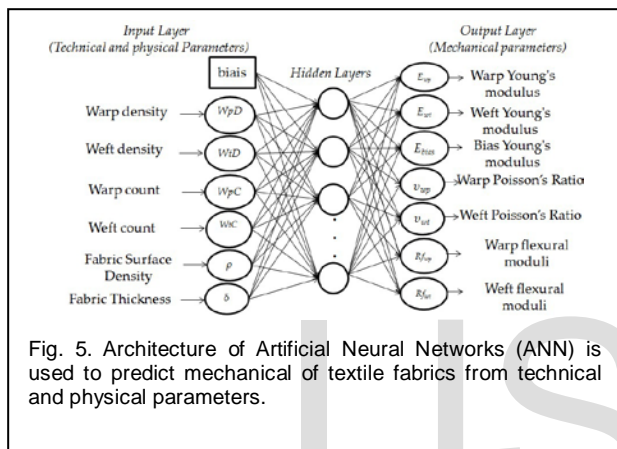

Fig. 5. Architecture of Artificial Neural Networks (ANN) is used to predict mechanical of textile fabrics from technical and physical parameters.

The parameters of the neural network to be optimized are:

- the number of neurons Nn
- the number of hidden layer HL
- the number of iterations N_i

The neural network architecture is shown in Figure. 5. This network is a feed-forward ANN trained with error back-propagation algorithm. The ANN weights and biases updating is carried out using the Levenberg-Marquardt optimization algorithm. The ANN optimality criteria are:

1. The correlation coefficient (R) between the predicted and measured values for each output.
2. The mean squares error (mse):

$$mse = \frac{1}{N} \sum_{i=1}^N (t_i - p_i)^2 \quad (16)$$

Where: N is the number of samples, t_i the target value, and p_i the predicted value.

The optimization of the neurons and hidden layers numbers is done in an incremental way using two algorithms developed in [20].

3.2 ANN-FEM Coupling

The ANN model is coupled with the physical model using the finite element method (*FEM-Model*) developed for the simulation of fabric drapemeter (Fig. 4). This would increase the efficiency of *ANN-model* and eliminate if not reduce the use of experimental characterization of mechanical properties of textile fabrics.

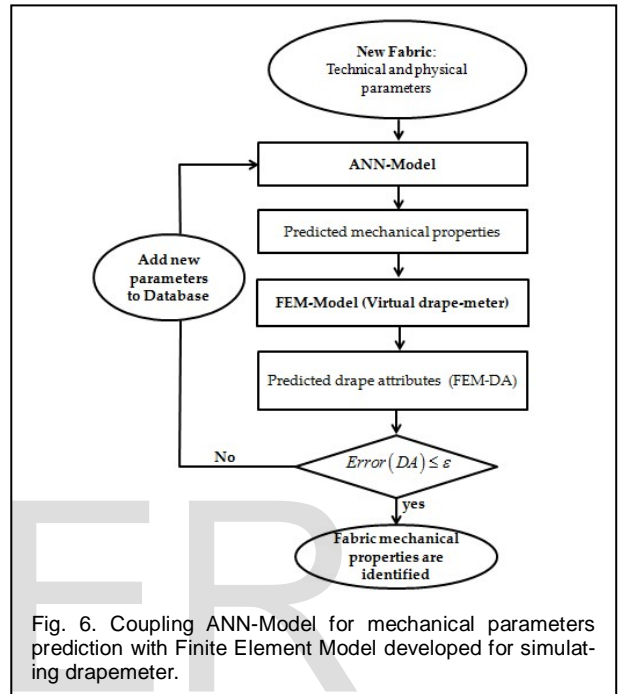

Fig. 6. Coupling ANN-Model for mechanical parameters prediction with Finite Element Model developed for simulating drapemeter.

4 RESULTS AND DISCUSSIONS

4.1 Validation Test of FEM-Model

To validate the model, we simulated the tensile tests on several types of fabrics of different weaves (plain, twill and satin) but identical composition (100% cotton).

The tensile test is carried out according to the french standard *NFG07-119*, also known as the simplified method. The displacement of the clamps is at constant speed (100 mm. mn^{-1}).

In our study, the Young's modulus is the slope of the linear part of the stress-strain curve (for elongation values of 10% to 40%).

The Young's modulus is a measure of the stiffness of the material to stretch/compression deformation.

The results show a great similarity between the experimental tests and the simulated ones. Indeed, this similarity is even more important that the stress-strain curve is linear (strain less than 0.3).

For this reason, the Young's moduli obtained by the simulations are very similar to those found experimentally.

The results of this investigation are included in Figures 7 (twill fabric), 8 (satin fabric) and 9 (plain fabric). The values of experimental and numerical Young's modulus are reported in Table 1.

Once the finite element model is validated, it is used to simulate the drape test and for the prediction of fabric drape attributes.

TABLE 1
 COMPARISON BETWEEN EXPERIMENTAL AND SIMULATED RESULTS FOR YOUNG'S MODULI DETERMINATION

	Experimental (MPa)			Simulated (MPa)		
	E_{wp}	E_{wt}	E_{bias}	E_{wp}	E_{wt}	E_{bias}
Twill	13.07	1.04	1.9	13.78	1.13	2.7
Satin	239.9	81.89	214	264.8	50	235
Plain	10	19.8	11.72	11.24	20.2	11.76

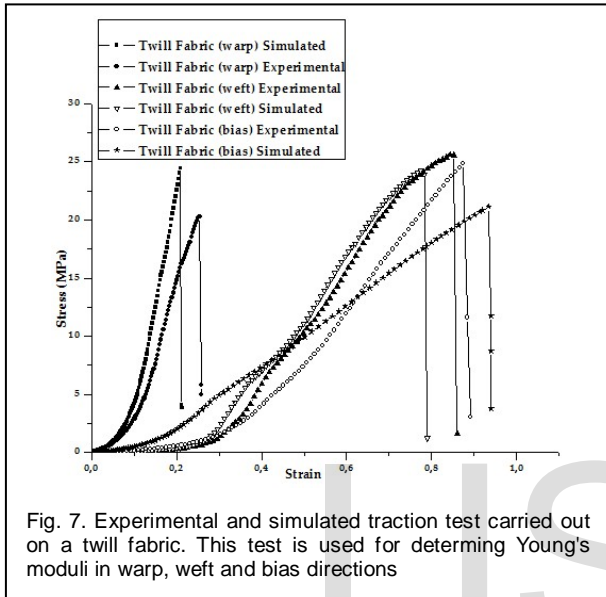

Fig. 7. Experimental and simulated traction test carried out on a twill fabric. This test is used for determining Young's moduli in warp, weft and bias directions

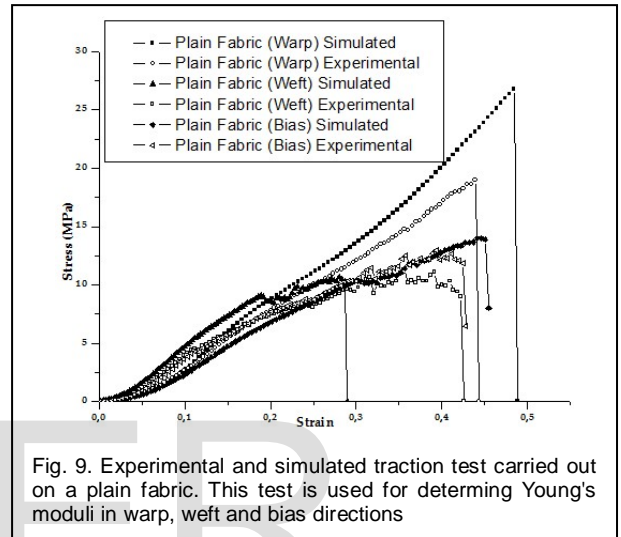

Fig. 9. Experimental and simulated traction test carried out on a plain fabric. This test is used for determining Young's moduli in warp, weft and bias directions

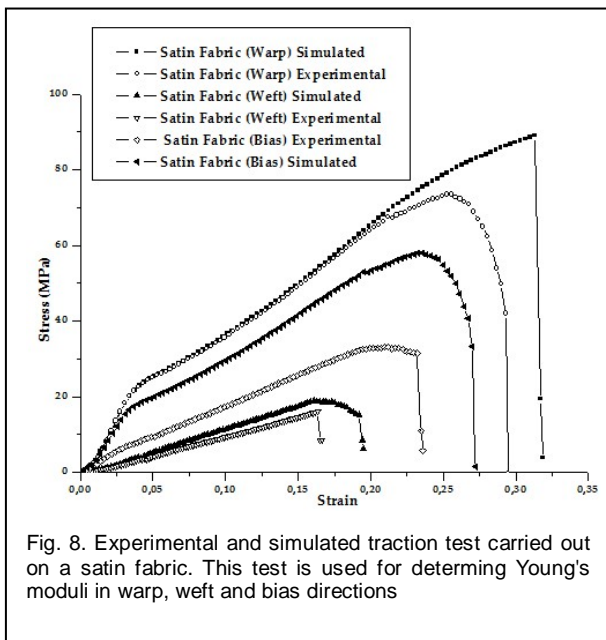

Fig. 8. Experimental and simulated traction test carried out on a satin fabric. This test is used for determining Young's moduli in warp, weft and bias directions

4.2 ANN Prediction of mechanical parameters

The ANN model is used to predict the mechanical properties of textile fabrics based on their technical parameters and physical properties. We obtained the following results:

1. A good ability to predict flexural modulus ($R_{f_{wp}}$ and $R_{f_{wt}}$) and the bias Young's moduli (E_{bias})
2. A lower capacity for predicting the Young's modulus (E_{wp} and E_{wt}) and Poisson's ratios (ν_{wp} and ν_{wt}) in warp and weft directions.

Figures 10 and 11 show an example of results obtained for flexural moduli ($R_{f_{wp}}$) and warp Young moduli (E_{wp})

Table 2 shows an example of results obtained on a plain fabric. The coefficient Error represents the error between the actual values of mechanical properties and those predicted by the neural network without ANN-FEM coupling. R denotes the correlation coefficient between the values predicted by the ANN on the test set.

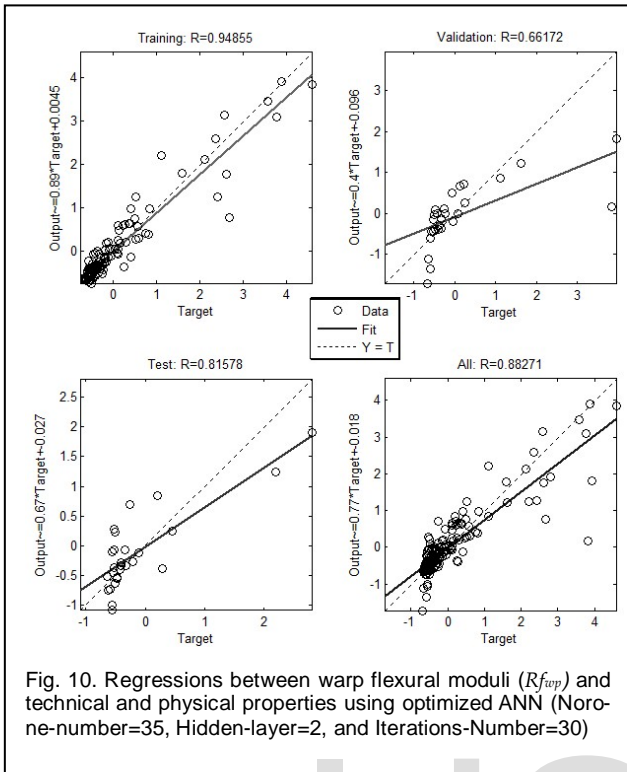

Fig. 10. Regressions between warp flexural moduli (R_{fwp}) and technical and physical properties using optimized ANN (Norne-number=35, Hidden-layer=2, and Iterations-Number=30)

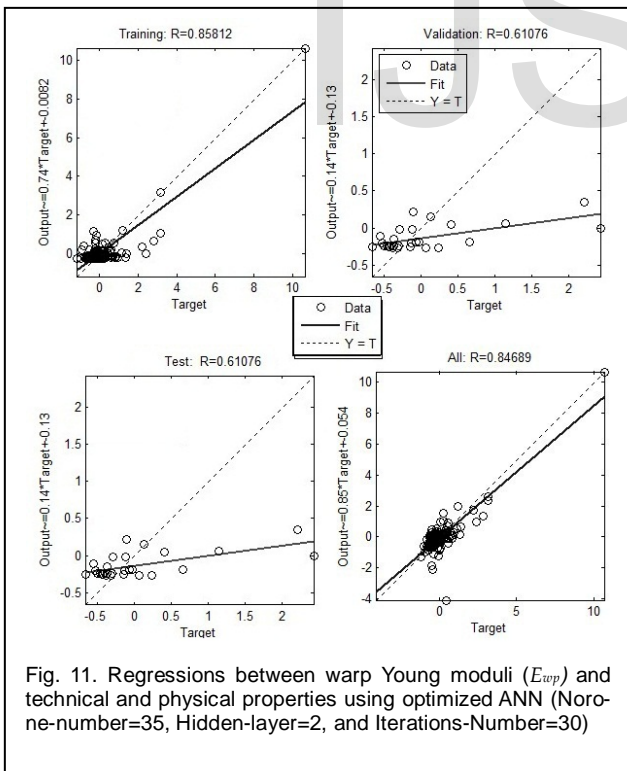

Fig. 11. Regressions between warp Young moduli (E_{wp}) and technical and physical properties using optimized ANN (Norne-number=35, Hidden-layer=2, and Iterations-Number=30)

4.3 Prediction using ANN-FEM coupling

ANN-FEM coupling is performed using the algorithm shown in Figure 6. This algorithm allows the identifica-

tion of mechanical parameters of fabric from technical and physical parameters and improves the predictability of the parameters related to the stretch behaviour: E_{wp} , E_{wt} , v_{wp} , and v_{wt} by simulating the drapemeter test. The algorithm is executed until the error between measured drape attributes and those found by the simulation becomes less than a limit value $\varepsilon = 10^{-2}$.

$$Error(DA) = \frac{\text{Predicted DA} - \text{Actual DA}}{\text{Actual DA}} \times 100 \quad (17)$$

Where, DA=DC, NN, DDR, ARR or FDI

The results obtained show the efficiency of coupling between the ANN model and FEM-model. Indeed, this coupling can increase the size of the training database by adding, new mechanical parameters obtained from the simulation based on the FEM model.

Figure 12 shows the evolution of the error on the prediction based on iterations of the ANN-FEM model. The number of iterations needed to improve the predictability varies from one parameter to another.

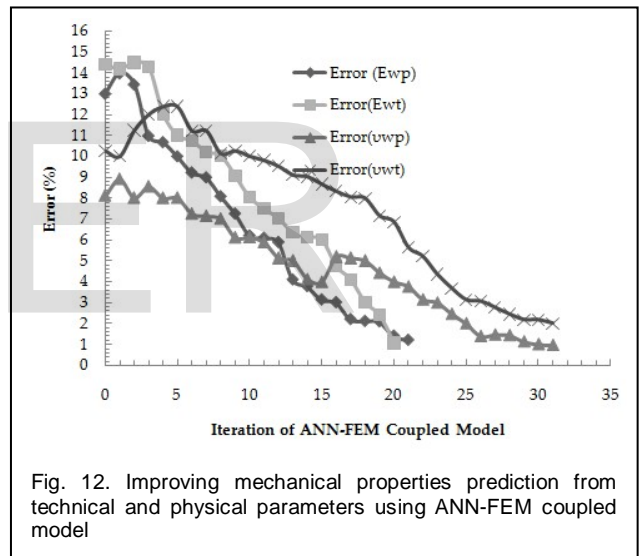

Fig. 12. Improving mechanical properties prediction from technical and physical parameters using ANN-FEM coupled model

TABLE 2
MECHANICAL PROPERTIES PREDICTABILITY USING ANN-MODEL

Mechanical properties	Error (%)	R
E_{wp} (MPa)	13.02	0.610
E_{wt} (MPa)	14.41	0.551
E_{bias} (MPa)	0.04	0.859
v_{wp}	8.11	0.641
v_{wt}	10.27	0.724
R_{fwp} (μNm)	0.0001	0.815
R_{fwt} (μNm)	0.0003	0.906

Table 3 shows an example of results obtained on a plain fabric. The coefficient Error represents the error between the actual values of mechanical properties and those predicted by the neural network using ANN-FEM coupling. R denotes the correlation coefficient between the values predicted by the ANN on the test set.

TABLE 3
 IMPROVING MECHANICAL PROPERTIES PREDICTABILITY USING ANN-FEM COUPLED MODEL

Mechanical properties	Error (%)	R
E_{wp} (MPa)	1.2	0.84
E_{wt} (MPa)	1.07	0.86
E_{bias} (MPa)	10^{-4}	0.97
ν_{wp}	0.97	0.81
ν_{wt}	2.01	0.89
Rf_{wp} (μNm)	10^{-4}	0.96
Rf_{wt} (μNm)	2.10^{-4}	0.98

Figure 13 and 14 show the results of applying our method to improve the predictability of the parameters E_{wp} and Rf_{wp} by coupling ANN-FEM models.

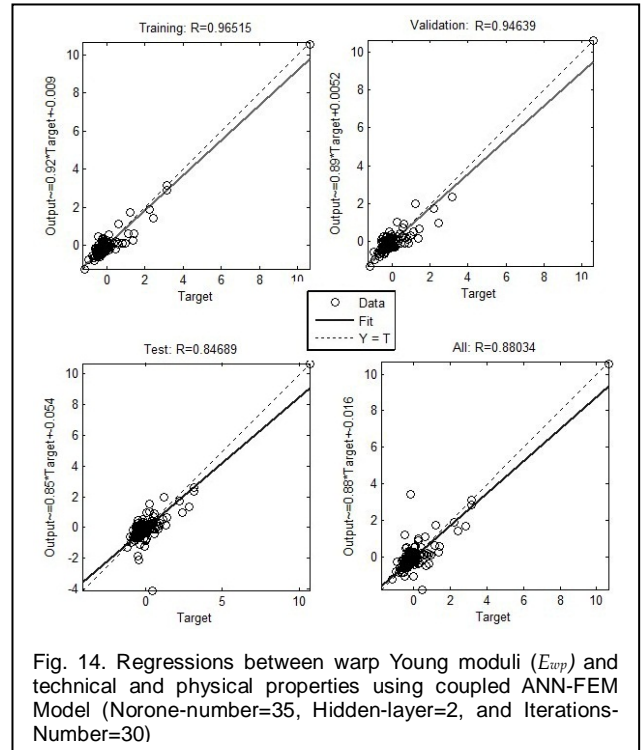
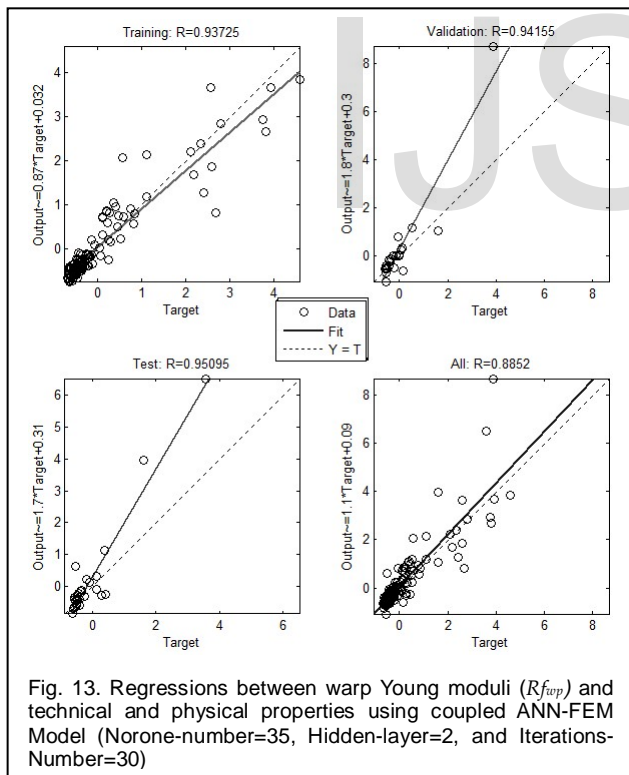

Fig. 14. Regressions between warp Young moduli (E_{wp}) and technical and physical properties using coupled ANN-FEM Model (Norone-number=35, Hidden-layer=2, and Iterations-Number=30)

5 CONCLUSION

In this paper, the objective is to predict with great efficiency the mechanical properties of textile fabrics from their technical parameters (warp and weft yarn counts and warp and weft yarn densities), and from two easily measurable physical properties (thickness and mass density). The prediction was based on the use of artificial neural networks.

The problem encountered when using the ANN model is the low predictability of properties related to the tensile-compression behavior of fabric mainly Young's modulus and Poisson's ratios in warp and weft directions.

The idea is to improve the predictability of these parameters by increasing the training database of neural network by adding data obtained from the simulated tests.

Indeed, a finite element model simulating the dynamic behavior of textile fabrics is developed and validated. This model is then used to simulate the drape meter.

The originality of this work is:

1. Reduce the use of mechanical tests to characterize textile fabrics
2. Replace these tests with virtual simulations.
3. Make good use of artificial neural networks by coupling them with finite element models describing the dynamic behavior of textile materials.

This approach can be improved by adding fuzzy logic rules to decide about the acceptance and the incorporation of the identified parameters in the training database.

6 REFERENCES

- [1] Hearle, J., W., S. "From Biological Macromolecules to Drape of Clothing: 50 Years of Computing for Textiles". Vol. 55, *chez Studies in Computational Intelligence (SCI): Computational Textile*, de X. Zeng, Y Li, D. Ruan et L. Koehl, 1-19. Berlin, Heidelberg: Springer-Verlag, 2007.
- [2] Hu, J., L., et J., G. Teng. "Computational fabric mechanics: Present status and future trends", *Finite Elements in Analysis and Design* 21 (1996): 225-237.
- [3] Tokumaru, M., N. Muranaka, and S. Imanishi, "Virtual Stylist project - examination of adapting clothing search system to user's subjectivity with interactive genetic algorithms", *The 2003 Congress on Evolutionary Computation*, 2003. CEC '03. Canberra, Australia: IEEE, 8-12 Dec. 2003. 1036-1043.
- [4] Guerlain, Ph., and B. Durand, "Digitizing and measuring of the human body for the clothing industry", *International Journal of Clothing Science and Technology* 18, n° 3 (2006): 151-165.
- [5] Hu, Z-H., Y-S. Ding, W-B. Zhang and Q. Yan, "An interactive co-evolutionary CAD system for garment pattern designs", *Computer-Aided Design* 40 (2008): 1094-1104.
- [6] Volino, P., F. Cordier, and N. Magnenat-Thalmann, "From early virtual garment simulation to interactive fashion design", *Computer-Aided Design* 37 (2005): 593-608.
- [7] Fontana, M., C. Rizzi, and U. Cugini, "3D virtual apparel design for industrial applications", *Computer-Aided Design* 37 (2005): 609-622.
- [8] Meng, Y., P., Y. Mok, and X. Jin, "Interactive virtual try-on clothing design systems", *Computer-Aided Design* 42 (2010): 310-321.
- [9] Lau, T., W., Patrick, C., L. Hui, Frency, S., F. Ng, and Keith, C., C. Chan, "A new fuzzy approach to improve fashion product development", *Computers in Industry* 57, n° 1 (2006): 82-92.
- [10] Hadjianfar, M, and D. Semnani, "Fuzzy classification of luster of textile fabrics", *Textile Research Journal* 81 (2011): 649-656.
- [11] Vassiliadis, S., M. Rangoussi, A. Cay, and C. Provatidis, "Artificial Neural Networks and Their Applications in the Engineering of Fabrics", Chap. 6 in *Woven Fabric Engineering*, edited by P., D. Dubrovski, 112-134. Rijeka, Croatia: Sciyo, 2010.
- [12] Hui, C., L., P., N., S. Fun, and C. Ip, "Review of Application of Artificial Neural Networks in Textiles and Clothing Industries over Last Decades", Chap. 1 in *Artificial Neural Networks - Industrial and Control Engineering Applications*, edited by K. Suzuki, 3-34. Rijeka, Croatia: InTech, 2011.
- [13] Tehran, M-A, and M. Maleki, "Artificial Neural Network Prospectives in Textile Applications", Chap. 2 in *Artificial Neural Networks - Industrial and Control Engineering Applications*, edited by K. Suzuki, 35-64. Rijeka, Croatia: InTech, 2011.
- [14] Stylios, G., K., N., J. Powell, and L. Cheng, "An investigation into the engineering of the drapability of fabric", *Transactions of the Institute of Measurement and Control* 24 (2002): 33-50.
- [15] Lam, A., A. Raheja, and M Govindaraj, "Neural network models for fabric drape prediction" *2004 IEEE International Joint Conference on Neural Networks*. Australia: IEEE, 25-29 July 2004. 2925-2929.
- [16] Behera, B., K., and R. Mishra, "Artificial neural network-based prediction of aesthetic and functional properties of worsted suiting fabrics", *International Journal of Clothing Science and Technology* 19, n° 5 (2007): 259-276.
- [17] Jedda, H., Ghith, A., and Sakli, F, " Prediction of fabric drape using the FAST system", *Journal of the Textile Institute* 98, n° 3 (2007): 219-225.
- [18] Pattanayak, A., K., A. Luximon, and A. Khandual, "Prediction of drape profile of cotton woven fabrics using artificial neural network and multiple regression method", *Textile Research Journal* 81 (2011): 559-566.
- [19] Hedfi, H., Ghith, A., and BelHadjSalah, H., "Dynamic fabric modelling and simulation using deformable models", *Journal of the Textile Institute*, 102 (8), First published, 647-667, 2011.
- [20] Hedfi, H., Ghith, A., and BelHadjSalah, H., "Intelligent Evaluation of Fabrics' Elastic Properties from Simulated Drape Test", *International Journal of Computer Technology and Applications*, Vol 2 (4), 741-749